

Neon Specification

ANF3D1010

Neon Specification

ANF3D1010



Feature

1. Top bending design with 10mm luminous surface, uniform light and no light spot, suitable for indoor and outdoor decorative lighting, architectural outline lighting, etc.
2. Silicone integrated extrusion technology, IP67 rate.
3. Normal silicon gel end caps and integrated forming end caps two solution are available.
4. Using high quality gas silica gel, yellowing resistance, UV resistance, salt and alkali resistance, high temperature resistance, flame retardant.



-  Min. Bending Radius 60mm / 2.36in
-  Min. Cutting Length 14.29mm @White
-  Ambient Working Temperature -40 ~ 55°C
-  Storage Temperature -40 ~ 60°C

Electrical & Output Data

Model No.	ANF3D1010					
Step length (mm)	14.29mm (@white)					
Voltage (v)	24V					
Color	2100K	2700K	3000K	3500K	4000K	6000K
Ra	90					
Beam Angle(°)	110					
Power (w/m)	10W(@white)					
Lumen(lm/m)	590 @10Watt @ Ra90 @ 4000K					
IP rate	67					
Installation	Mounting Clips / Aluminum Profiles					

The electrical data provided on the each product pages are for reference only; the data values are not guaranteed. Specification may be subject to change without announcement.

Illuminance Distribution

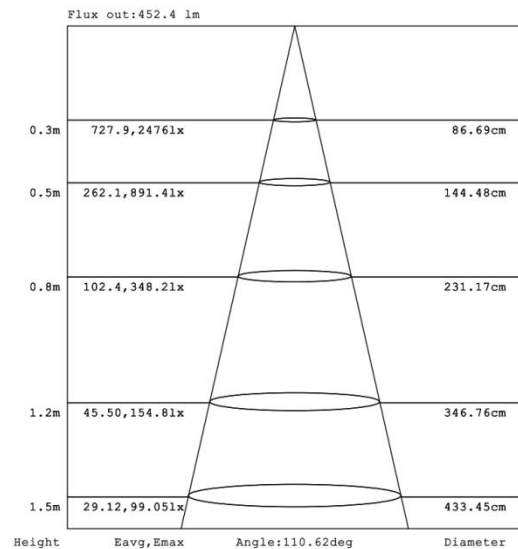
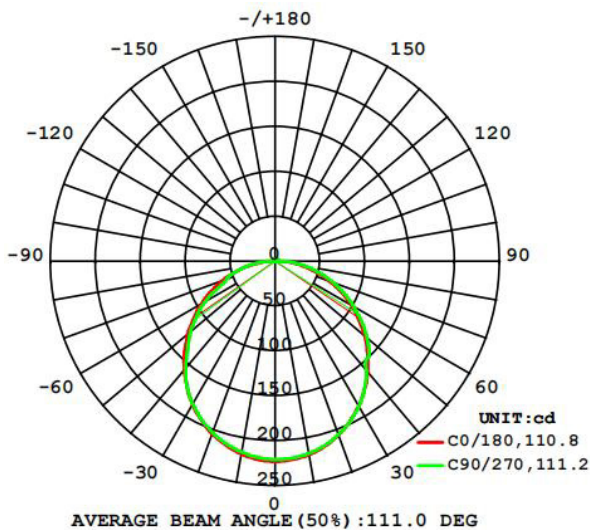

Light efficiency & Lumen Output

Item No.	Color temperature	Ra	Beam angle	Luminous flux (lm/m)	Luminaire efficacy (lm/W)	Power (W/M)
ANF3D101012W46	2100K	90	110°	470	47	10W/M
ANF3D101012W24	2700K	90	110°	530	53	10W/M
ANF3D101012W06	3000K	90	110°	550	55	10W/M
ANF3D101012W08	4000K	90	110°	590	59	10W/M
ANF3D101012W04	6000K	90	110°	580	58	10W/M

Dimensions & available lengths

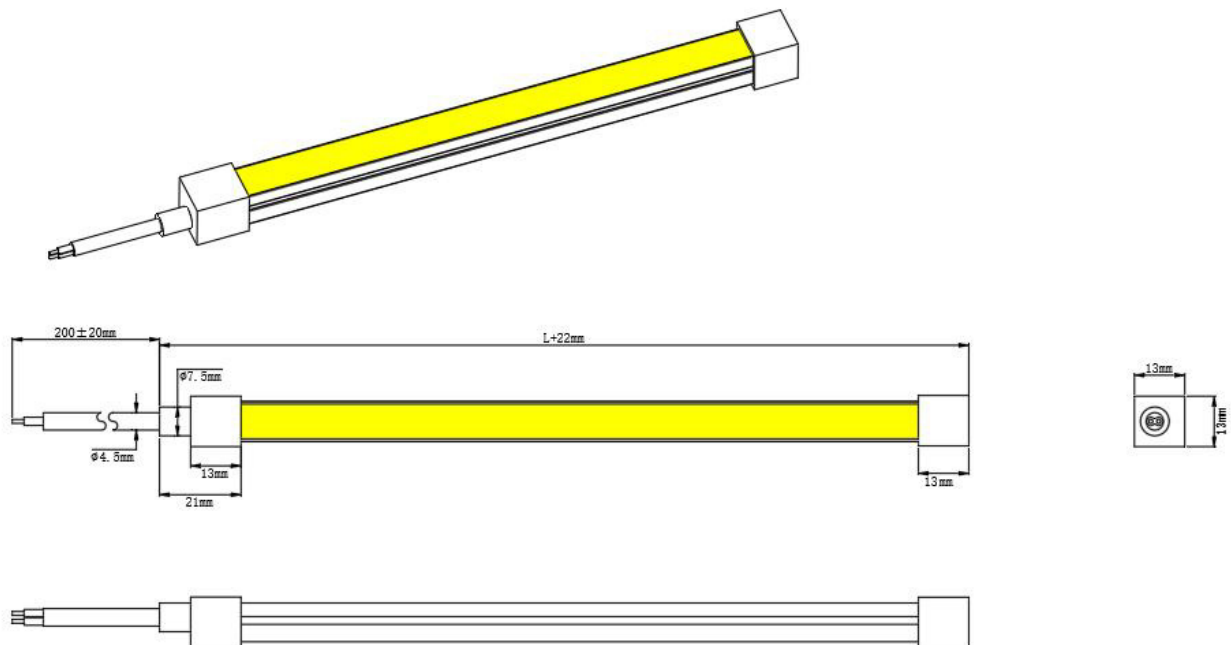

Note: The length of "L" is the length of the light strip, which is an integer multiple of the minimum cutting length.

Max. Running Length



Type IP Rate	White 67 10Watt
Item Code	Single-end
max.length (m)	9.16% @5M 18.45% @7M 26.85% @9M 31.69% @10M

Note:

1. Above conclusion is based on voltage drop testing result of the light with 200mm cable only.
2. The maximum running length is based on the light in static full loading status.
3. Above running length is only the light length excluding lengths of connectors.
4. The delivery length might be subject to the maximum packing length.

ANF3D1010 Mounting Profile

Name/Item Code	Picture	Installation Way			
Install aluminum clips ANFZ1010A04 L30*W11.6*H11.9mm					
Aluminum Profile ANFZ1010A03 L1000*W11.6*H11.9mm					
Bendable Serrated Profile ANFZ1010A06 L1000*W11*H10.2mm					

ANF3D1010 Wiring Diagram

Please use a constant voltage power supply with corresponding output voltage, and rated wattage of the power supply shall be 25% more than the actual power consumption of light to increase its life expectancy;

1. This wiring diagram is using the mains of AC 220-240V with brown and blue wires as an example, and please connect with the corresponding live and neutral wires for other mains electricity;
2. Dimming frequency ranges from 100Hz to 2000Hz, and 500Hz is recommended.

Light Length:

The length of the longest single light in parallel connection or sum of lights in series connection.

Cable Length:

The length of an electrical cable between power output end and light input end, and the cables for serial interconnection are inclusive.

How to Minimize Voltage Drop:

1. Please ensure the cable length is not more than the table "Max. Cable Length" according to light length and its wire gauge.
2. Please ensure the light length is less than the cable "Max. Running Length Single-end Feed".

Single-end Feed

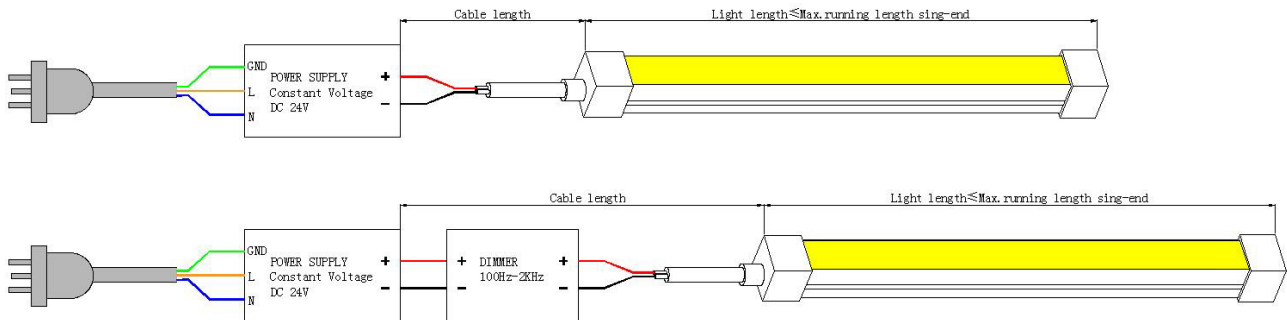

Double-end Feed

The following wiring diagram with double-end feed to run length that is longer than max. running length for single-end feed but less than twice the value.

WARNING

Please ensure the polarity connection is correct on both ends, and short circuit might occur if powering the light from both ends with reverse polarity. It is not recommended to feed both ends of light with two separated power supplies, which would lead to overloading and overheating problem if either power supply is failed.

Light Length:

The length of the longest single light in parallel connection or sum of lights in series connection.

Cable Length:

The length of an electrical cable between power output end and light input end, and the cables for serial interconnection are inclusive.

How to Minimize Voltage Drop:

1. It is optimal to position the power supply in the middle of a single light or multiple lines in daisy chain to keep the equivalent cable length on both ends for double-end feed.
2. Please ensure the cable length is not more than the table "Max. Cable Length" according to the half of light length and its wire gauge.
3. Please ensure the light length is less than the table "Max. Running Length Double-end Feed".

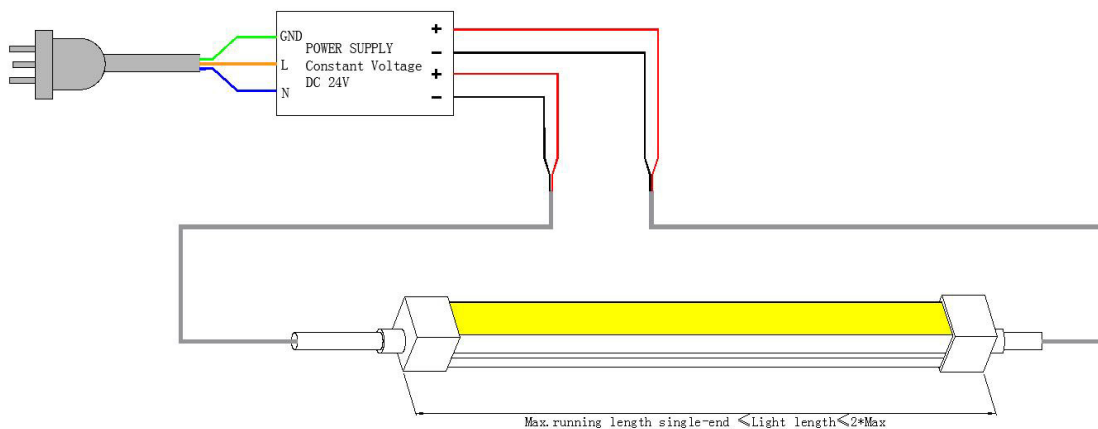

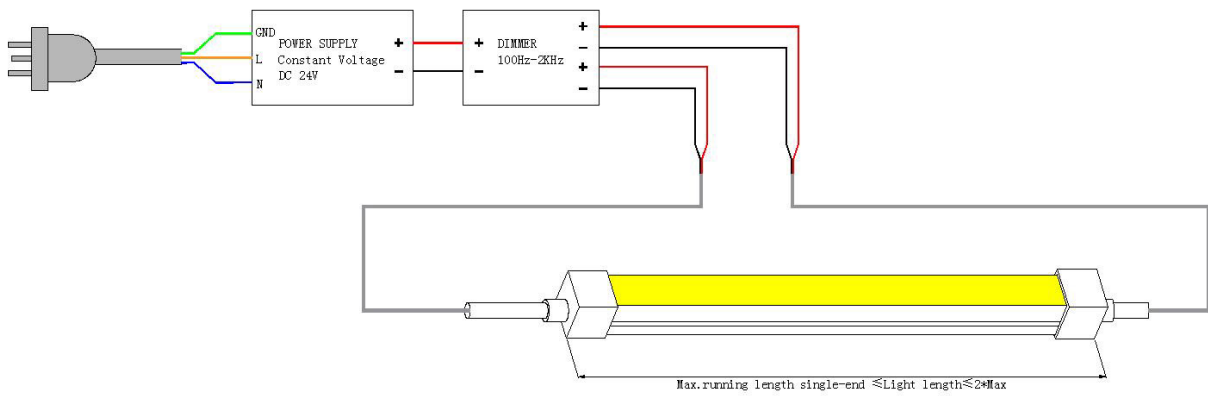

ConnectorType

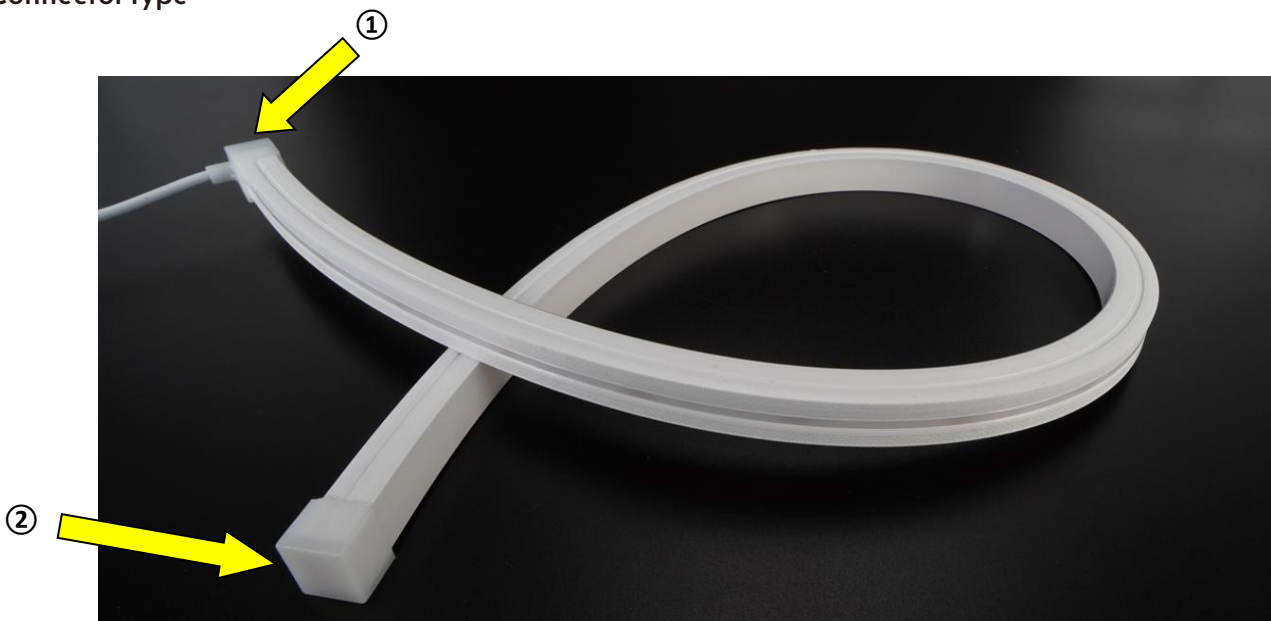

1 Outlet waterproof End Cap



Top



Right

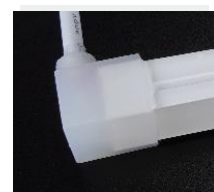

Bottom



Injection-moulded

2 No outlet waterproof End Cap

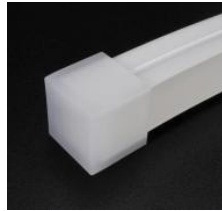

End cap
ANFZ1010A13



Injection-moulded

Dimension: mm

Waterproof End Cap-Top

ANFZ1010A10

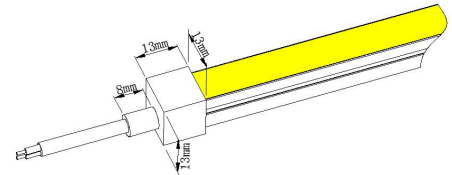
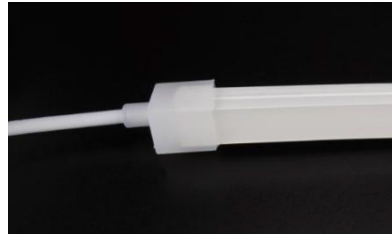

Waterproof End Cap-Right

ANFZ1010A11

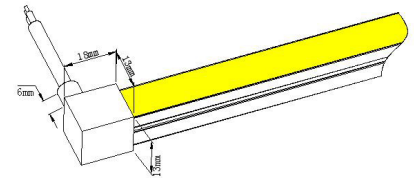

Waterproof End Cap-Bottom

ANFZ1010A11

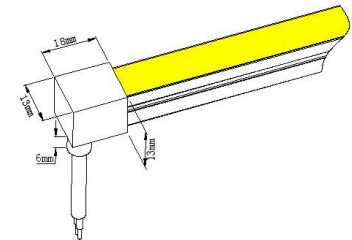

Waterproof End Cap
-Injection-moulded-Top

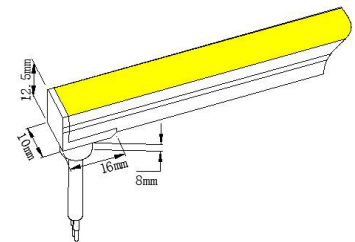

Waterproof End Cap
-Injection-moulded-Right

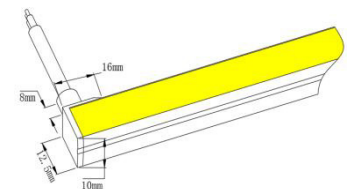

Waterproof End Cap
-Injection-moulded-Bottom

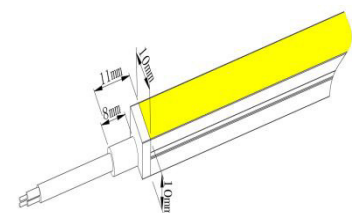

Note: To avoid damage from the excessive force on cable joint, please keep at least 60mm of cable ahead in the natural state.

Install aluminum clips



It uses high-quality 6063 aluminum with thin-wall, lightweight design to fit tightly the light body. It is deformation and rust resistant, and cost-effective.

Please refer to the applicable installation ways.

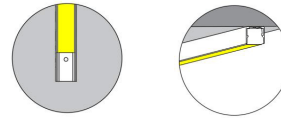

Dimension: mm

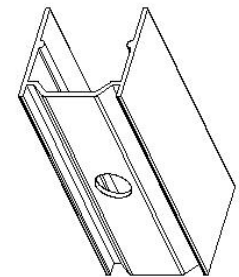
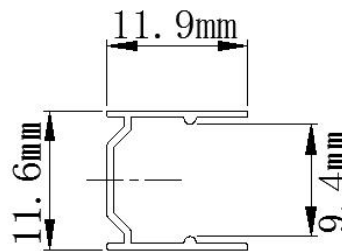
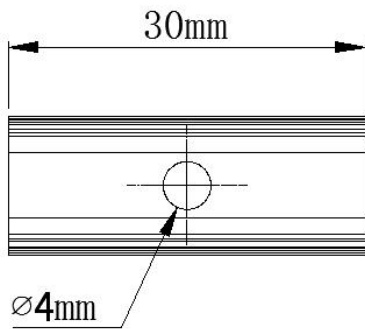

Item Code	Standard Length	Slotted Hole	Hole Number
ANFZ1010A04	30mm/1.18in	Ø4mm/Ø0.16in	1

Aluminum Profile



It uses high-quality 6063 aluminum with thin-wall, light-weight design to fit tightly the light body. It is deformation and rust resistant, and cost-effective.

Please refer to the applicable installation ways.

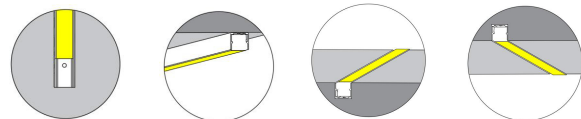

Dimension: mm

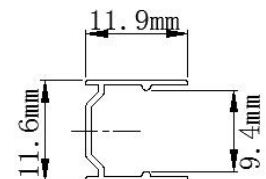
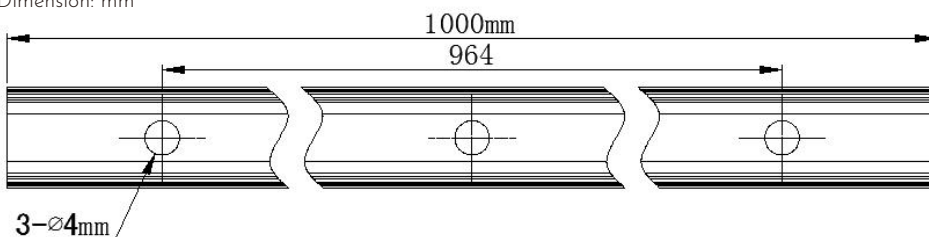

Item Code	Standard Length	Slotted Hole	Hole Number
ANFZ1010A03	1000mm/39.4in	Ø4mm/Ø0.16in	3

Bendable Serrated Profile



It is an expanded design of the serrated profile, and caters for the continuously streamlined aesthetics of curve shape. The secondary precision cutting process, not only maintains the advantage of clamping force, but also enables the two-way horizontal bending directions with super shape memory.

Please refer to the applicable installation ways.

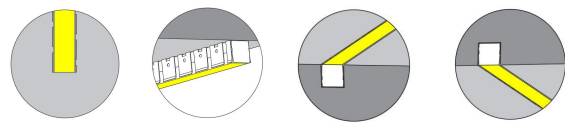

Dimension: mm

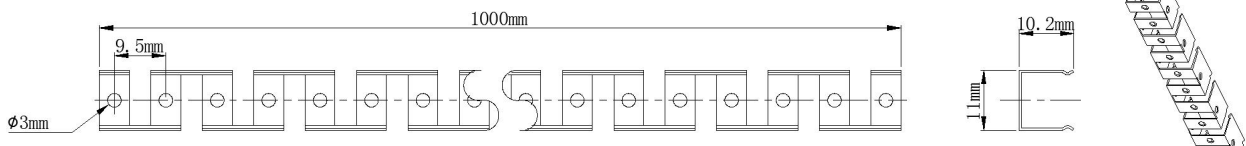

Item Code	Standard Length	Slotted Hole	Hole Number
ANFZ1010A06	1000mm/39.4in	Ø3mm/Ø0.12in	105

Installation Instructions

Friendly Reminder: please read instructions carefully before operation.

Installation

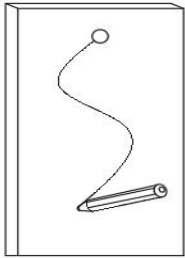

Mark the required shape on the mounting surface or print the sketch in the scale of 1:1 if complicated.

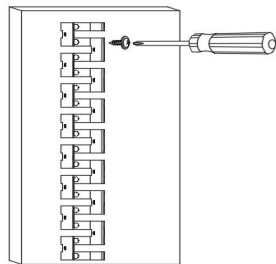

Get the front connector outside of profile and keep at least 10mm more apart. Fix the screw starting from the power input end.

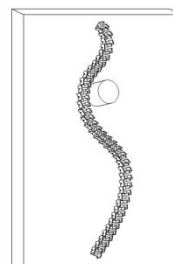

Use cylinder or disc-like object you have to assist with shaping.

Bending Diameter

Min. Bending Diameter

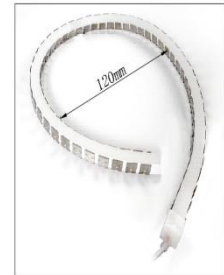

Fix the rest in sequence along with the marks.



Adjust the serrate silicone tape and remove the redundant lengths at both ends



Finish and fix the light in.

Profile Installation

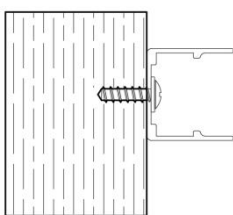

Install the screw into position and ensure the screw head is in line with or lower than the base of aluminum profile.

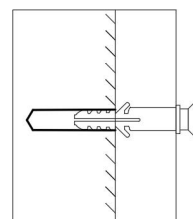

Place the rubber expansion bolt to assist with the screw fixation if the mounting surface is rigid.



Make sure no debris in the profile before installation to avoid the light housing being impaled and cause water ingression.

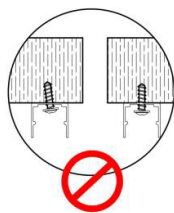

Make sure no bulges on the slot to avoid the damage on the light and cause water ingression.



Do not use the profile deformed seriously.

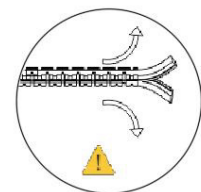

It's recommended to mount in place at a time when using the bendable aluminum profile in case of any break due to the frequent repeated shaping.

Profile Jointing

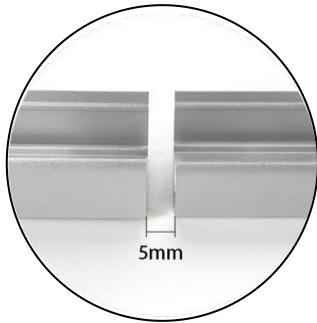

1. Please reserve at least 5mm for profile jointing to enable enough space for contraction and expansion.

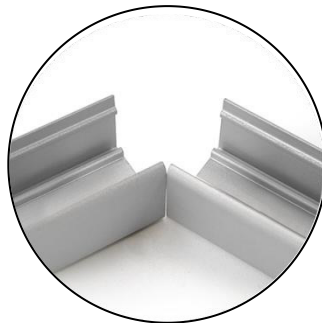

2. The profile can be jointed to a right angle only if there are two pieces of lights connected to be a right angle.



3. For the curve shaping of light, make sure to leave enough space to separate profiles in between or use the bendable profile instead.

4. Splice Structure on Mounting Surface



Angular Misalignment



Parallel Vertical Misalignment



Parallel Horizontal Misalignment



In the case of an outdoor mounting surface with the splice structure, please make sure the mounting profile goes across the gap or separate the light and profile as per the splice structure.



When the profile jointing lies where the mounting surface splices, contraction and expansion of the mounting surface in the long term will cause the misalignment of profiles and lights, and lead to the damage of inside PCB.

Above wrong misalignments will make the light improperly bent, and lead to the wrinkle or fracture on PCB.

Light Installation

It's not recommended to install the light repeatedly, otherwise the light inside might be damaged.

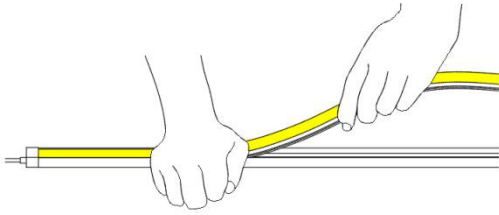

Make sure the light is fitted in vertically.

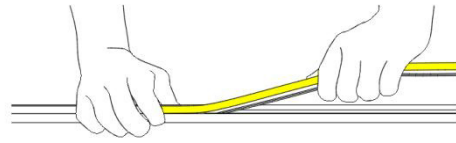

Press the light into the profile by the palm instead of the finger, otherwise it might damage inside electronic components due to the overpressure caused.

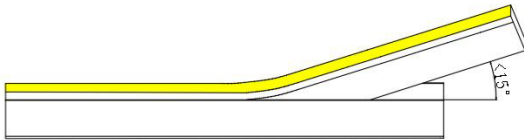

Make sure the angle between the light and profile is not bigger than 15°, otherwise inside PCB might be damaged.

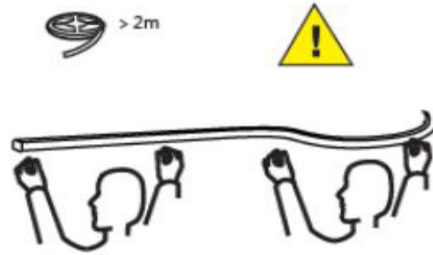

When light length >2m, make sure somebody helps to lift the light, in case the heavy weight of light itself generates too small bending angle or twisting, which may damage inside PCB.

Light Uninstallation

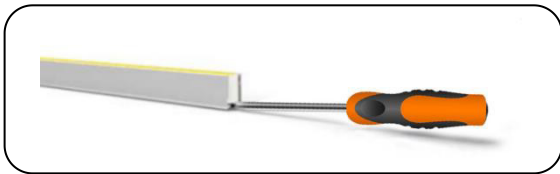

Prepare a screwdriver, and put the screwdriver at the bottom of light.



Move the screwdriver and unclench the light upwardly. Be careful the angle between the light and profile should not be bigger than 15°.

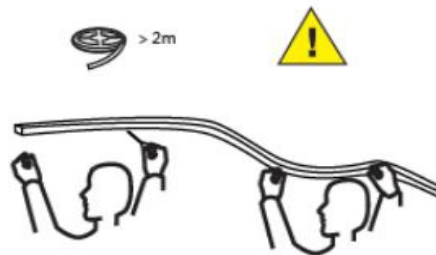
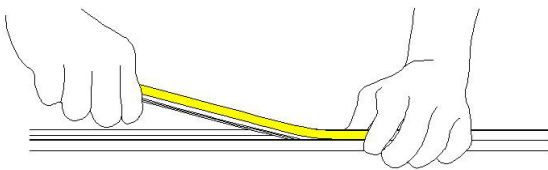

Once the end of light is out, hold both sides of light by hand and pull it out along the profile slowly and orderly. Make sure the angle between the light and profile is not bigger than 15°, otherwise inside PCB might be damaged.

When light length >2m, make sure somebody helps to lift the light, in case the heavy weight of light itself generates too small bending angle or twisting, which may damage inside PCB.

